

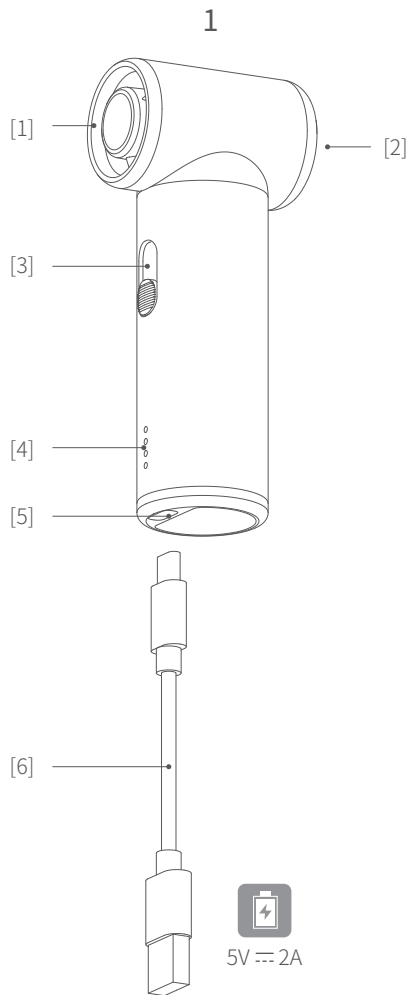



Portable Fan Instructions



EN / CN / DE / FR / ES / IT /
PT / RU / JP / KR / PL



[1]	Air outlet 吹风口 Luftauslass Orifice de soufflage Salida de aire Uscita dell'aria Saída de ar Поддувальное отверстие 吹出口 공기 배출구 Wylot powietrza	[2]	Suction port 进风口 Lufteinlass Orifice d'admission Entrada de aire Ingresso dell'aria Entrada de ar Воздухозаборник 吸気口 공기 흡입구 Wlot powietrza
[3]	Speed control button 调速键 Taste zur Geschwindigkeitsregelung Touche de régulation de vitesse Botón de control de velocidad Pulsante della velocità Botão de controle de velocidade Кнопка регулировки скорости 風速調整ボタン 속도 조절버튼 Przycisk regulacji prędkości	[4]	Indicator 指示灯 Anzeigelampe Voyant Luz indicadora Luce dell'indicatore Luz indicadora Индикаторная лампа ランプ 전원 표시등 Wskaźnik
[5]	Charging port 充电口 Anschluss zum Aufladen Interface de charge Puerto de carga Porto di ricarica Porto de carregamento Порт для зарядки 充電ポート 충전단자 Port ładowania	[6]	USB-C cable Type-C 充电线 Typ-C-Ladekabel Câble de charge de type-C Cable USB-C Linea di ricarica Type-C Cabo de carga tipo C Кабель для зарядки Type-C Type-C 充電ケーブル Type-C 충전케이블 Kabel typu C

2

 Power off 关机 Ausschalten Arrêt Apagado Spegnimento Desligar Выключение 電源オフ 전원 끄기 Wyłączenie zasilania	 Low speed 低速 Niedrige Drehzahl Basse vitesse Baja velocidad A bassa velocità Velocidade baixa Низкая скорость 低速 저속 Niska prędkość
---	---

 Medium speed 中速 Mittlere Geschwindigkeit Vitesse moyenne Velocidad media Velocità media Velocidade média Средняя скорость 中速 중속 Średnia prędkość	 High speed 高速 Hohe Geschwindigkeit Haute vitesse Alta velocidad Alta velocità Alta velocidade Высокоскоростной 高速 고속 Duża prędkość
--	---

3

 Full battery / Charge completed 満電 / 充電完成 Volle Batterie/ Ladevorgang abgeschlossen Pleine capacité électrique / Chargement terminé Bateria llena / Recarga terminada Bateria piena / Ricarica completa Bateria cheia / Carregamento completo Полный заряд батареи / Зарядка завершена フルバッテリー / 充電完了 만전 / 충전완료 Pełny akumulator / Ładowanie zakończono
--

 High battery level 高电量 Hoher Batteriestand Électricité élevée Nivel de batería alto Livello di batteria alto Nivel de batería alto Высокий уровень заряда батареи バッテリーレベルが高い 배터리 잔량이 높음 Wysoki poziom naładowania baterii

 Medium battery level 中电量 Mittlerer Batteriestand Puissance moyenne Nivel de batería medio Livello di batteria medio Nivel de batería médio Средний уровень заряда батареи バッテリーレベルが中程度 배터리 잔량이 중간 Średni poziom naładowania baterii
--

 Low battery level 低电量 Niedriger Batteriestand Faible quantité d'électricité Nivel de batería bajo Livello di batteria basso Nivel de batería baixo Низкий уровень заряда батареи バッテリーレベルが低い 배터리 잔량이 낮음 Niski poziom naładowania baterii

 Charging 正在充电 Ladevorgang läuft Chargement en cours En carga A carregar А зарядка 充電中 충전중 Ładowanie

 Need recharging 需要充电 Aufladen erforderlich Avoir besoin de recharger Necesitar recarga Necessità di ricarica Precisa ser carregado Нужно заряжать 充電が必要 충전필요 Potrzebne ładowanie

 Low power, will auto power off / Malfunction warning 电量耗尽, 即将关机 / 故障提示 Niedriger Stromverbrauch, schaltet sich automatisch aus/ Fehlerprompt Batterie faible, il s'éteindra automatiquement / Dépannage Baja potencia, se apagará automáticamente / Aviso de fallo Batteria scarica, in procinto di spegnersi / Richiesta di errore Bateria fraca, desligar-se-á automaticamente / Indicação de falha Низкий заряд батареи, сразу выключить / Подсказка о неисправности 低電力、電源がもうすぐ切れる / 故障のヒント 전량낮음, 꺼짐예정 / 고장알림 Niskie zasoby energii - nastąpi automatyczne wyłączenie zasilania / Ostrzeżenie o nieprawidłowym działaniu
--

 Off/ 熄灭 / Aus/Eteint/Apagado/Spento/Apagado/выключено/ 消灯 / 소등 / Wyłączone  Steady/ 常亮 / Konstant/Fixe/Constante/Fisso/Constante/ постоянный/ 点灯 / 지속 / Ciągłe  Blinking / 闪烁 / Blinkend/Clignotant/Intermittente/Lampeggiante/ Intermittente/мигающий/ 点滅 / 점멸 / Migające
--

4

Product name 产品名称	KiCA Portable Fan KiCA 便携风扇
Model 产品型号	KiCAPF
Battery capacity 电池容量	5000mAh
Charging time 充电时长	≈ 3h (5V/2A, 25°C)
Weight 主机重量	≈ 167g
Size 产品尺寸	112.6×47.6×31.7mm
Max. revolution speed 最高转速	40,000±10%rpm
Max. runtime 最长续航时间	≈ 15h

This document is subject to change without notice.
 说明书内容如有更新, 恕不另行通知。
 Der Inhalt der Betriebsanleitung kann ohne vorherige Ankündigung aktualisiert werden.
 Le contenu du manuel peut être modifié sans préavis.
 Este manual está sujeto a cambios sin previo aviso.
 Il contenuto del manuale è soggetto ad aggiornamenti senza preavviso.
 Este documento está sujeto a cambios sin previo aviso.
 Этот документ может быть изменен без предварительного уведомления.
 本取扱説明書の内容は予告なしに変更される場合があります。
 이 설명서의 내용은 예고 없이 업데이트될 수 있습니다.
 Zawartość podręcznika może być aktualizowana bez wcześniejszego powiadomienia.

Guilin Feiyu Technology Incorporated Company
 桂林飞宇科技股份有限公司
 www.kica-tech.com service@kica-tech.com
 Tel +86 773-2320865 电话 400-990-6118
 Version 1.0